

IMPORTANT INSTRUCTIONS

For Installation of LS6016

C.A.C.N. 010 572 773

www.lumascope.com

WARNING

DO NOT SHORTEN, INTERFERE OR DISCONNECT CABLE FROM FITTING. WARRANTY WILL BE VOID IF CABLE ASSEMBLY IS TAMPERED WITH.

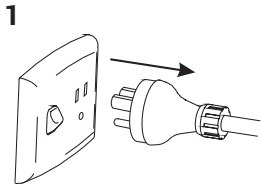

1
Ensure that the fixture is electrically isolated.

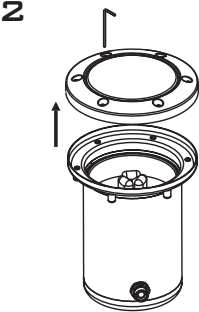

2
Open fixture using allen key or screwdriver.

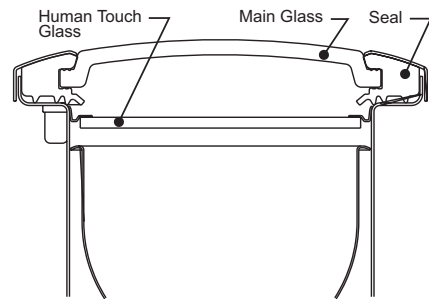
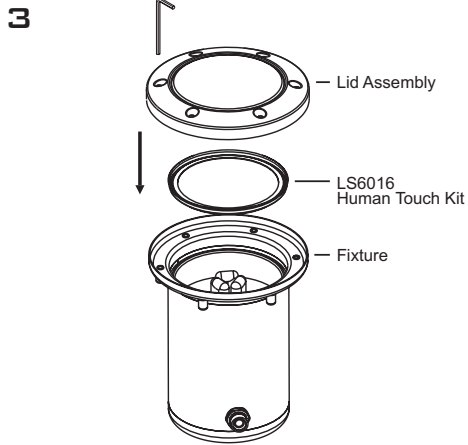

3
Insert Human Touch glass into fixture and reseal.

LUMASCOPE CONTACT DETAILS

C1081US - 2006_12_REV002

• LUMASCOPE USA INC. 1300 Industrial Rd., Unit #19 San Carlos, CA 94070, USA • Free Call: 1-866-695-LUMA(5862) • Ph: 1-(650)-595-LUMA(5862) • Fax: 1-(650)-595-5820

IMPORTANT INSTRUCTIONS

For Installation of LS6016

C.A.C.N. 010 572 773

www.lumascope.com

WARNING

DO NOT SHORTEN, INTERFERE OR DISCONNECT CABLE FROM FITTING. WARRANTY WILL BE VOID IF CABLE ASSEMBLY IS TAMPERED WITH.

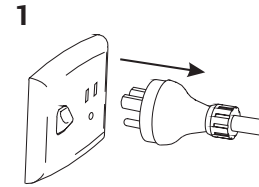

1
Ensure that the fixture is electrically isolated.

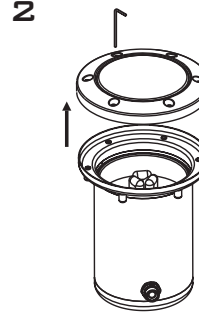

2
Open fixture using allen key or screwdriver.

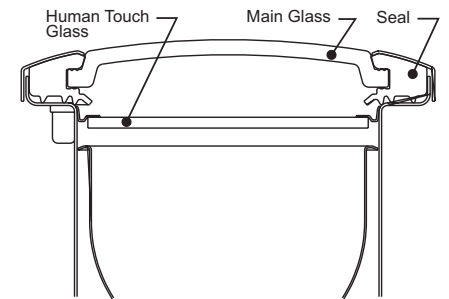
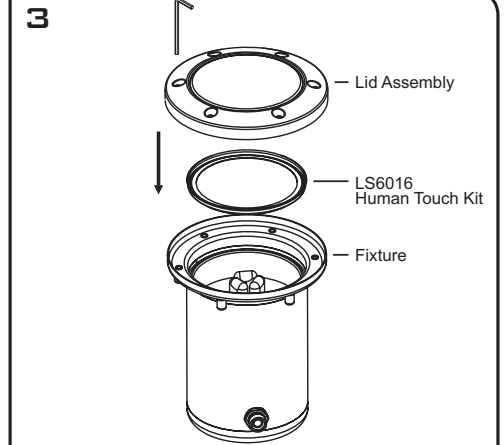

3
Insert Human Touch glass into fixture and reseal.

LUMASCOPE CONTACT DETAILS

C1081US - 2006_12_REV002

• LUMASCOPE USA INC. 1300 Industrial Rd., Unit #19 San Carlos, CA 94070, USA • Free Call: 1-866-695-LUMA(5862) • Ph: 1-(650)-595-LUMA(5862) • Fax: 1-(650)-595-5820