

**A** **IMPORTANT INSTRUCTIONS**  
 For Installation LS464LED DOWNLIGHT

Warning: The Luminaire should only be used complete with its protective shield (cover)

**Lumascap Lighting Industries Pty Ltd**  
 38-44 Enterprise Street, Cleveland, QLD 4163, Australia  
 PO Box 1875, Cleveland D.C., QLD 4163, Australia  
 T 07 3286 2299  
 F 07 3286 6599  
 E sales@lumascap.com.au  
 W www.lumascap.com.au

**WARNING: DO NOT USE POWER TOOLS TO ASSEMBLE OR FASTEN.  
 DO NOT REMOVE CABLE OR GLAND FROM FITTING**

**1 A**

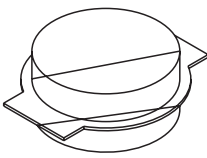

If using Pre Installation Kit LS6063-K, follow instructions supplied with LS6063-K then go to step 2

**1 B**

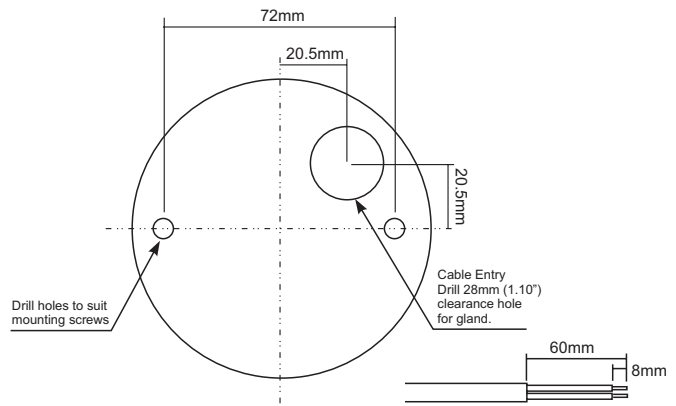

Drill holes to suit mounting screws

Cable Entry  
 Drill 28mm (1.10")  
 clearance hole for gland.

Mark locations of fixtures. Mark and drill/cast holes. Strip supply cable as above. See attached full sized template.

**2**

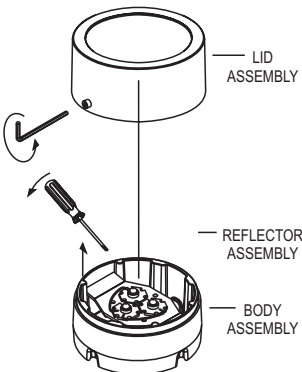

LID ASSEMBLY

REFLECTOR ASSEMBLY

BODY ASSEMBLY

Unscrew grub screw and remove lid assembly.

**3**

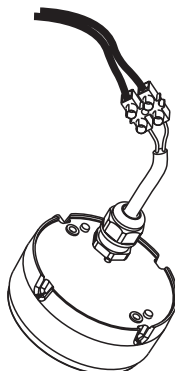

Terminate behind fitting.  
**DO NOT REMOVE CABLE OR GLAND FROM FITTING.**

**4**

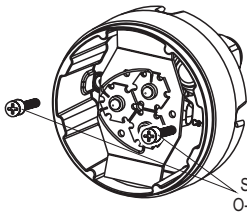

SMALL O-RINGS

Secure fixture with screws and o-rings supplied - do not use power tools - screw by hand to prevent oring/gasket damage.

If Using Pre Installation Kit LS6063-K, be sure to properly locate screw holes in cast in plate after removing foam blockout.

Note: Check that oring is seated correctly.

**5**

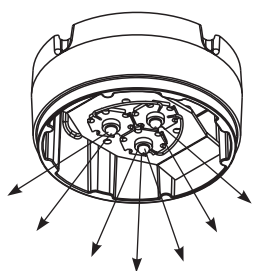

Warning: LED's are fragile take care when installing.  
 Avoid contact with LED lenses.  
 Avoid any contact with inside of glass.

**6**

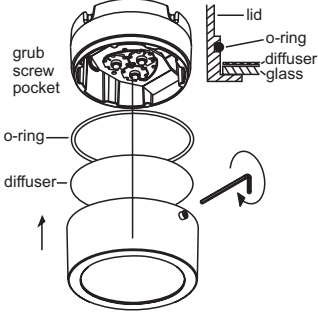

lid

o-ring

diffuser

glass

grub screw pocket

o-ring

diffuser

Check and clean all sealing areas. Ensure Oring is in groove in lid. Ensure diffuser is in place against glass. Re-Seal fixture. Ensure that lid is pushed up as far as possible so that o-ring seals. Grub screws should be flush if fixture is assembled correctly.

## IMPORTANT SAFETY INSTRUCTIONS

### WARNING - To reduce the risk of FIRE or INJURY:

1. Luminaires and transformers to be installed by qualified installers only.
2. Luminaires to be used for intended purpose only. e.g Wall Mount fittings must be wall mounted.
3. Luminaires can become very hot. Use discretion in placement.
4. Do not touch hot lens, guard, or enclosure.
5. CAUTION - HOT SURFACE. Keep away from curtains and other combustible material.
6. Turn Off/Unplug and allow to cool before replacing lamp.
7. Keep lamp away from materials that may burn.
8. Never touch lamp with bare fingers. Oil from skin may damage lamp. Hold lamp with soft cloth when installing or replacing.
9. Do not operate the luminaires with a missing or damaged parts.
10. Replace any cracked protective shield
11. Use only lamp type, voltage and wattage as specified by Lumascap on the product label.
12. Use only genuine Lumascap parts to replace damaged or missing components.
13. Luminaires supplied with Loctite Silver Grade Anti Seize lubricant on threads. Reapply if needed.
14. Refer to instructions for installation and operating requirements.
15. Ensure installation complies with local regulations

### SAVE THESE INSTRUCTIONS.

**A** **IMPORTANT INSTRUCTIONS**  
For Installation LS464

Warning: The Luminaire should only be used complete with its protective shield (cover)

Lumascap Lighting Industries Pty Ltd  
38-44 Enterprise Street, Cleveland, QLD 4163, Australia  
PO Box 1875, Cleveland D.C., QLD 4163, Australia  
T 07 3286 2299  
F 07 3286 6599  
E sales@lumascap.com.au  
W www.lumascap.com.au

**WARNING: DO NOT USE POWER TOOLS TO ASSEMBLE OR FASTEN.  
DO NOT REMOVE CABLE OR GLAND FROM FITTING**

**Mounting Template, 1:1**

