

Caution and Safety Instructions



- Turn off power at the fuse or circuit breaker before installation or servicing.
- Qualified personnel must install and/or service this product in a manner consistent with its intended use and in compliance with the National Electrical Code, Canadian Electrical Code, and/or all local and provincial codes.
- Follow all product label information and installation instructions.
- The use of damaged components may cause an unsafe condition and void the product warranty.
- Keep all O-rings and sealing surfaces clean during installation and servicing; failure to do so may lead to premature failure of this product.

Product Information

- This product is suitable for mounting at grade level.

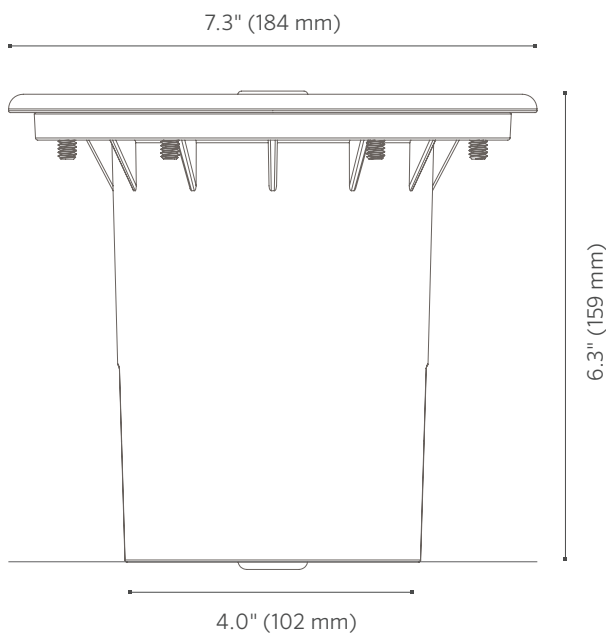

Tools Needed for Installation:

- #3 Phillips screwdriver
- 5/32" Allen wrench
- 5/64" Allen wrench

Product Installation

Figure 1

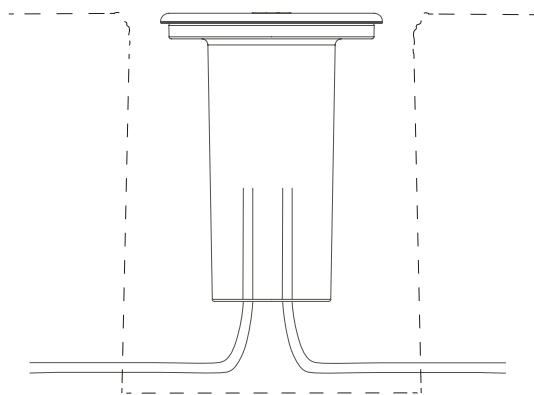
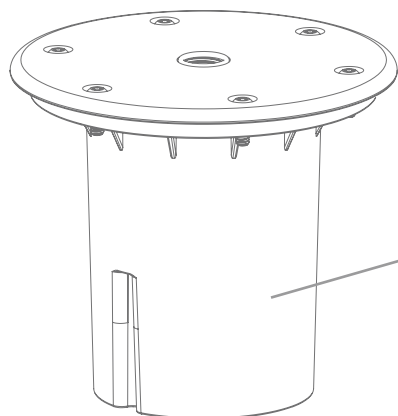
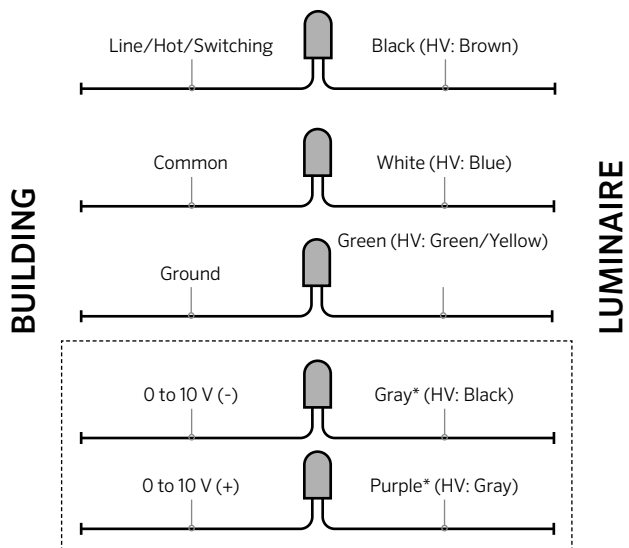

Figure 2



Wiring Chart



*For use with 0 to 10 V driver only

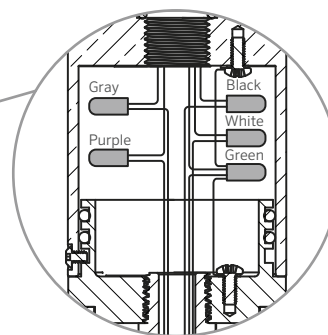

Power Requirements

	North America (SV)	International (HV)
Input Power	120 Vac, 60 Hz	220 to 240 Vac, 50 Hz

Product Installation

Figure 3

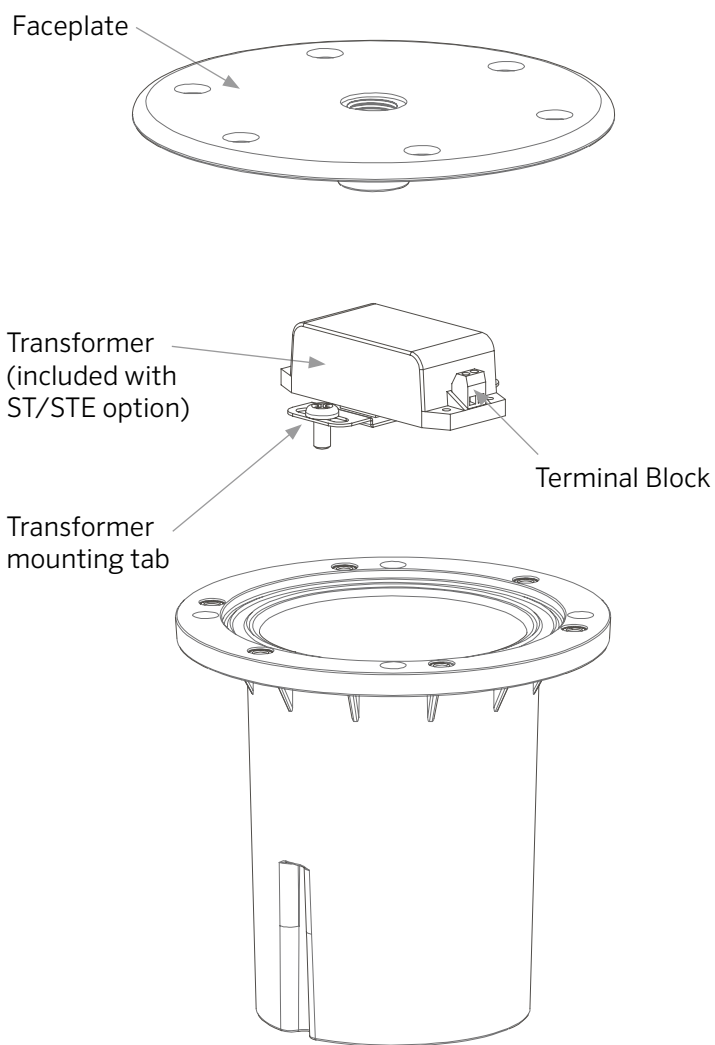

1. Secure the driver housing in-ground in accordance with local codes and regulations (Figure 1).
2. Connect conduit or cable runs to the bottom of the driver housing with couplings ($\frac{1}{2}$ "-14 NPT; not included). Use the provided $\frac{1}{2}$ "-14 NPT plug for unused conduit openings.
3. Add the installation cover onto the driver housing with the provided fasteners to prevent dirt and debris from entering the driver housing (Figure 2).
4. To complete the installation, use double-sided tape to secure the transformer to the transformer mounting tab (Figure 3).
5. Use $\frac{1}{4}$ "-20 x $\frac{3}{8}$ " screws to secure the transformer mount to the inside bottom of the housing with a #3 Phillips screwdriver (Figure 3).
6. Connect the luminaire/conduit/cable (not included) to the $\frac{1}{2}$ "-14 NPT opening of the faceplate. Install the included O-ring gasket (Figure 3).
7. Use the wiring diagram and approved wire connectors to connect the transformer wiring.
8. Tighten the 8-32 x $\frac{1}{2}$ " setscrew using a $\frac{5}{64}$ " Allen wrench to lock the rotational position of the luminaire to the driver housing faceplate.
9. Seal the driver housing compartment using the provided gasket and fasteners ($\frac{1}{4}$ "-20 x $\frac{3}{4}$ " screws) with a $\frac{5}{32}$ " Allen wrench.

Warranty

STATEMENT OF LIMITED WARRANTY

Hunter Industries Incorporated (“Hunter”) warrants Lumascape lighting products to be free of defects in materials or workmanship under normal use for a period of five (5) years from the date of invoice. If a defect in a Lumascape product is discovered during the applicable warranty period, Hunter will repair or replace, at its option, the product or the defective part. This limited warranty does not extend to repairs, adjustments, or replacement of Lumascape products or parts resulting from misuse, negligence, alteration, modification, tampering, or improper installation and/or maintenance of the product. This warranty extends only to the original installer of the product. If a defect arises in a Lumascape product or part during the warranty period, contact the local authorized manufacturer’s representative. Hunter’s obligation to repair or replace its products as set forth above is the sole and exclusive warranty set forth by Hunter. There are no other warranties, expressed or implied, including warranties of merchantability and fitness for a particular purpose. Hunter will not be liable to distributor or any other party in strict liability, tort, contract, or any other manner for damages caused or claimed to be caused as a result of any design or defect in Lumascape products, or for any special, incidental, consequential, or exemplary damages of any nature, including without limitation lost business or profits. Notwithstanding the foregoing, if for any reason Hunter is found to be liable, in no event shall Hunter’s liability exceed the price of the product which gives rise to the claim, loss, or damage.

If you have questions concerning the warranty or its application, email info@lumascape.com.

