



A **START** **HERE** **IMPORTANT INSTRUCTIONS**
For Installation LS275LED Underwater LED

Warning: The Luminaire should only be used complete with its protective shield (cover)

LUMASCAPE USA INC
1300 Industrial Rd, Unit #19
San Carlos, CA 94070, USA
T 1-(650)-595-LUMA(5862)
F 1-(650)-595-5820
E info@lumascope.com
W www.lumascope.com Free Call 1-866-695-LUMA(5862)

1

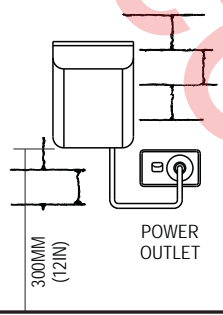

300MM (12IN)
POWER OUTLET

Use an isolating type transformer and overcurrent protection for the secondary circuit as per The National Electrical Code (NEC).
Mount suitable transformer, (12v AC Magnetic transformer only) in appropriate location

2

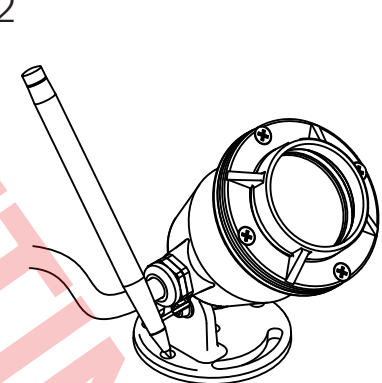
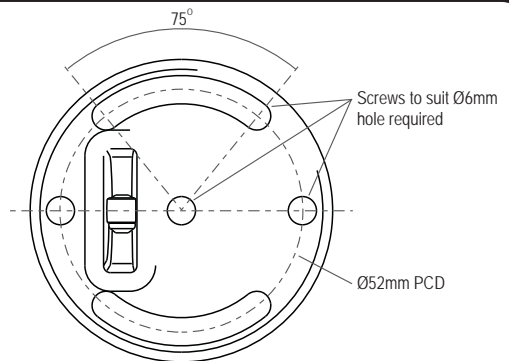



75°
Screws to suit Ø6mm hole required
Ø52mm PCD

Mounting Base Dimension Details

Position fixtures and mark mounting hole locations. Drill holes to suit fasteners suitable for substrate, (Not supplied).

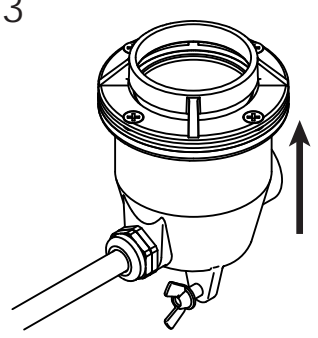
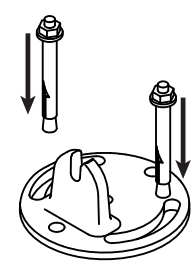
3

Loosen wing nut on pivot and remove base from fixture.
Attach fixture base to surface using appropriate fasteners.

4

Re-install fixture onto base

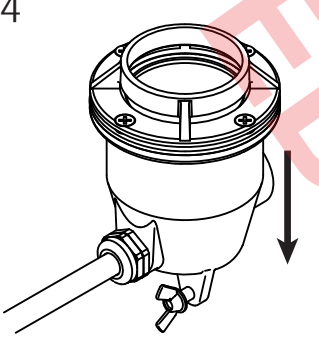
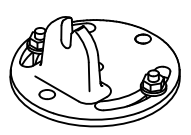
5

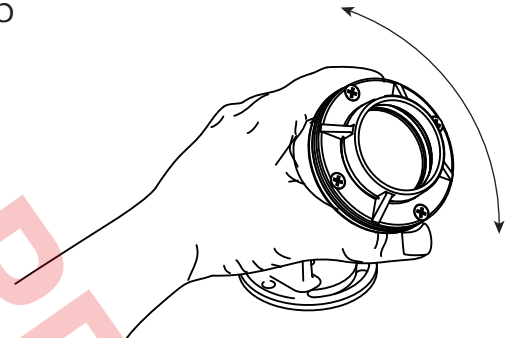

Aim fixture to required angle and tighten wing nut to fix.

IMPORTANT NOTE:
8W configuration must be submersed in order to operate.
Inbuilt Thermal Protection will turn fixture off if operated out of the water.