

IP Rating	IP30
Mourning	DIN Rail or Direct Mount
Operating Temp	-40°C to 50°C (-40°F to 122°F)
Input Voltage	12-30V DC
Interface	Rotary Switches / USB-C Port
Input Protocols	DMX, DALI, 0-10V (Sink or Source)
Output Protocols	DMX, PWM (100-1600 Hz, Invertable)



DANGER

ISOLATE DEVICE FROM POWER

Failure to isolate power supply before installation or maintenance may result in fire, serious injury, electric shock, death and may damage the device.



Product Warranty is void if product is not installed as per installation instructions and in compliance with the local electrical code.



READ ALL SAFETY INSTRUCTIONS FIRST

- › Follow instructions carefully; failure to do so will void warranty.
- › Ensure installation complies with local laws and applicable standards.
- › Keep free from debris and in an easily accessible location.
- › Only use Lumascope power supplies, and leader cables.
- › Ensure mains input power is surge protected. **Never make connections whilst power is connected.**
- › Do not make modifications or alter product.
- › Connections and LS6560 are to be kept clean and dry at all times.

Products and specifications are subject to change without notice.
LS6560_INT_NA_IN0289_260408

LS6560 is a lighting protocol converter that can be used to translate the signals and protocols listed below. For detailed setup instructions refer to the specific page number.

INDEX

Overview 3

DMX to PWM 4

DALI to PWM 5

DALI to DMX Generic 6

DALI to DMX with LS6540 Data Injector 7

0-10V Sinking to PWM (Use for LS6122 Wall Plate Dimmer) 8

0-10V Sourcing to PWM 9

0-10V Sinking to PWM - Using Lutron Nova T (NTSTV-DV) 10

PWM Settings 11

Compatible Products 11

Physical Installation - DIN Rail Mount 12

Physical Installation - Inside LS6540 13

Mode Table 14

OVERVIEW

LED Indicators

■ Power	Steady on. Indicates that device is powered up and operational.
■ Status	Flashing every 1 second. Indicates the unit is functioning normally.
■ DALI RX	Indicates incoming DALI traffic.
■ DALI TX	Indicates outgoing DALI traffic.
■ DMX RX	Indicates incoming DMX traffic. Turns off LED after 5 seconds of inactivity.
■ DMX TX	Indicates outgoing DMX traffic.
■ DIAG	Not used

Rotary Switches

Mode / Address Switch

Value	Mode
0-5	DMX to PWM
6	DALI to PWM
7	DALI to DMX
8	0-10V to PWM
9	Test Mode

PWM Settings

Value	PWM Frequency
0	100Hz
1	200Hz
2	400Hz
3	800Hz
4	1600Hz
5	Inv-100Hz
6	Inv-200Hz
7	Inv-400Hz
8	Inv-800Hz
9	Inv-1600Hz

Refer to page 11 for details

Address Switches

USB-C Port and Indicator LED

Terminals PWM

Terminals DALI

Terminals 0-10V

Terminals DMX

Power In
12-30 V DC
Min. supply current
500mA

Test Mode
Outputs a PWM test signal:
Ch1=10%
Ch2=20%
Ch3=30%
Ch4=40%

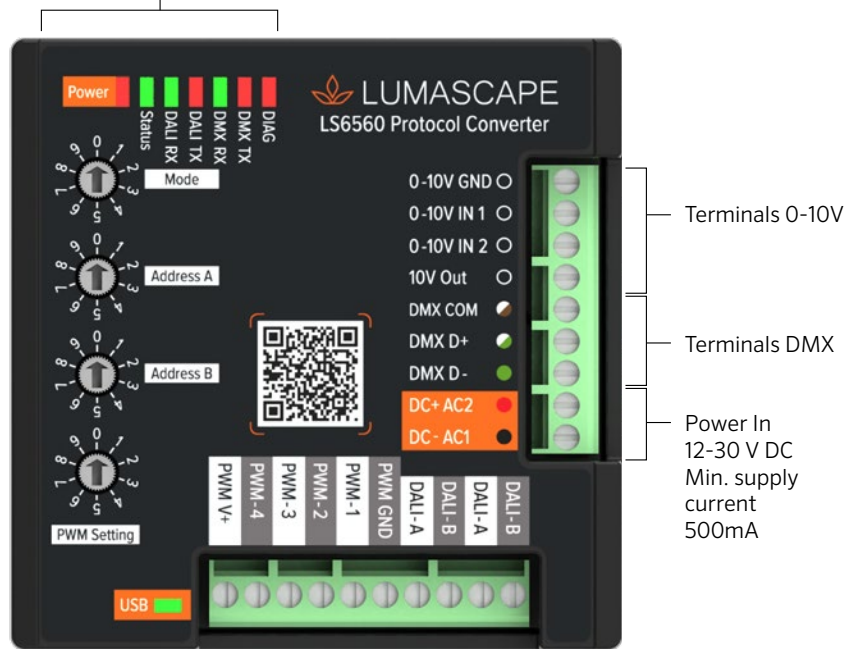

DMX to PWM

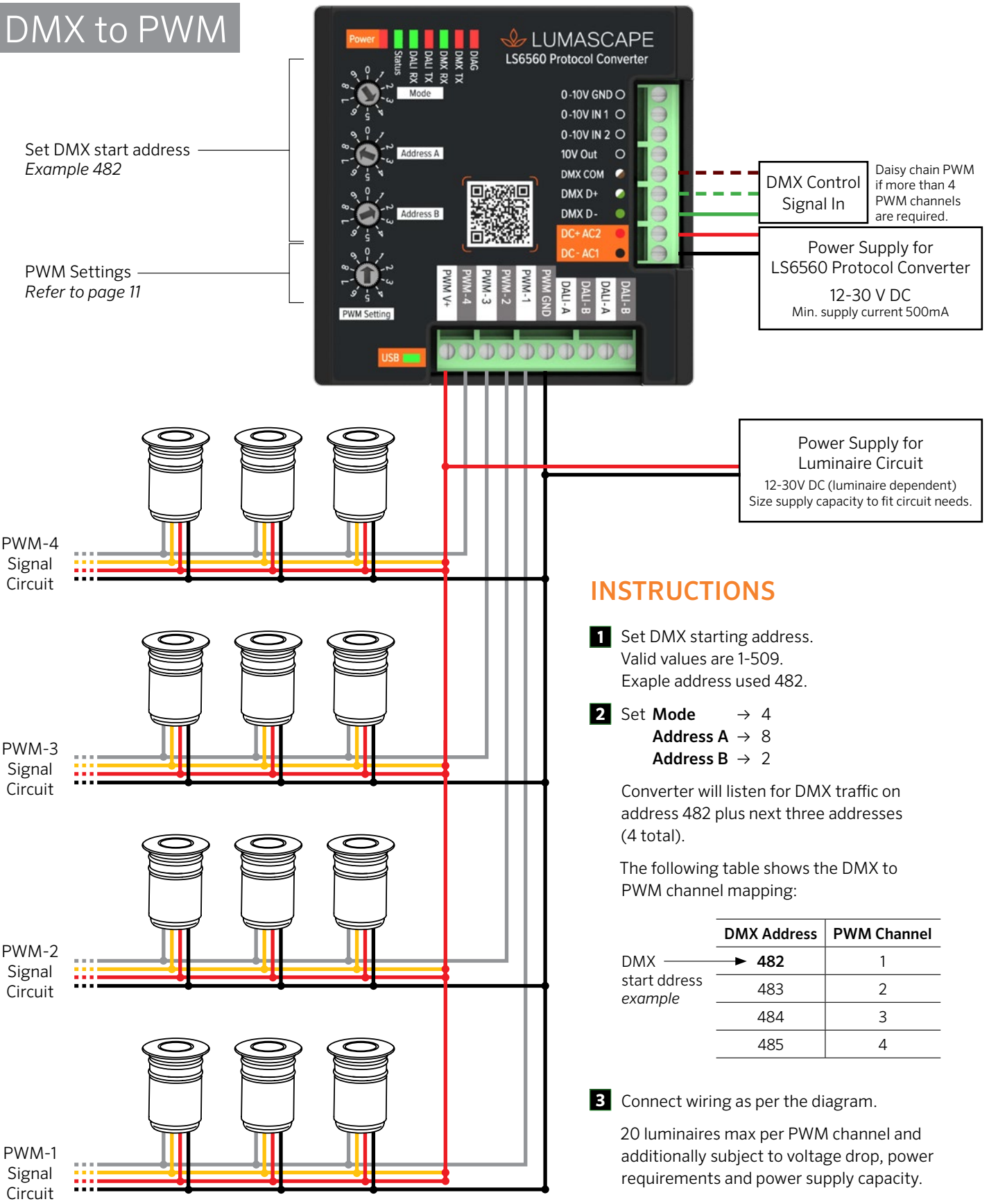

Set DMX start address
Example 482

PWM Settings
Refer to page 11

DMX Control Signal In
Daisy chain PWM if more than 4 PWM channels are required.

Power Supply for LS6560 Protocol Converter
12-30 V DC
Min. supply current 500mA

Power Supply for Luminaire Circuit
12-30V DC (luminaire dependent)
Size supply capacity to fit circuit needs.

INSTRUCTIONS

- 1** Set DMX starting address.
Valid values are 1-509.
Example address used 482.
- 2** Set **Mode** → 4
Address A → 8
Address B → 2

Converter will listen for DMX traffic on address 482 plus next three addresses (4 total).

The following table shows the DMX to PWM channel mapping:

	DMX Address	PWM Channel
DMX start address example	482	1
	483	2
	484	3
	485	4

- 3** Connect wiring as per the diagram.
20 luminaires max per PWM channel and additionally subject to voltage drop, power requirements and power supply capacity.
For use of PWM rotary switch refer to page 11

DALI to PWM

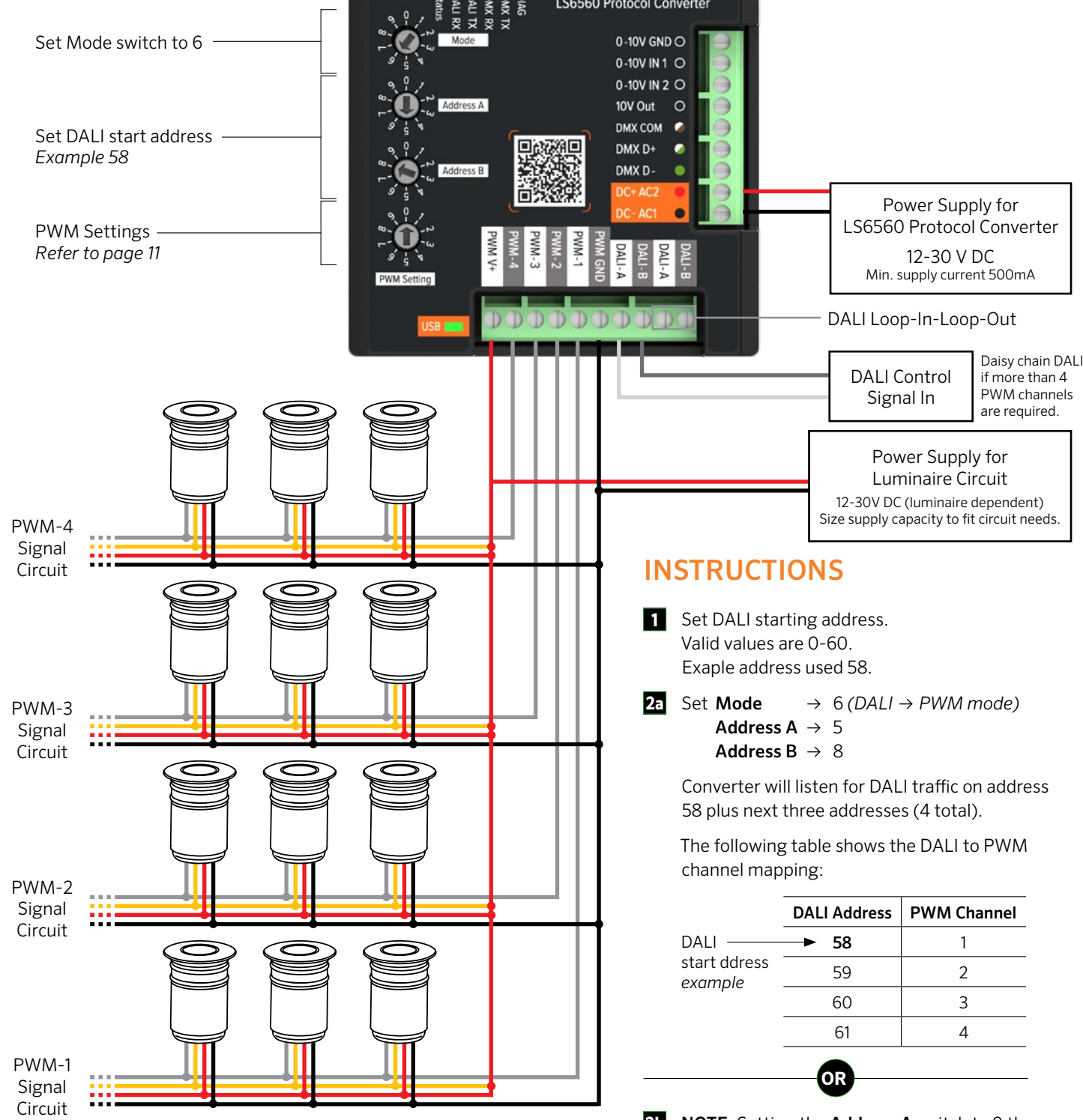

INSTRUCTIONS

- 1** Set DALI starting address. Valid values are 0-60. Example address used 58.
- 2a** Set **Mode** → 6 (DALI → PWM mode)
Address A → 5
Address B → 8

Converter will listen for DALI traffic on address 58 plus next three addresses (4 total).

The following table shows the DALI to PWM channel mapping:

	DALI Address	PWM Channel
DALI start address example	58	1
	59	2
	60	3
	61	4

OR

- 2b** **NOTE:** Setting the **Address A** switch to 9 the DALI starting address can be configured via application controller software.

- 3** Connect wiring as per the diagram.
 20 luminaires max per PWM channel and additionally subject to voltage drop, power requirements and power supply capacity.

For use of PWM rotary switch refer to page 11

FEATURES

- ✓ Support for linear or logarithmic dimming curve via Application Extended Commands (DT6 device)
- ✓ Support for standard DALI fade times, fade rates, fast fade times, and extended fade times.
- ✓ Supports broadcast, group and individual addressing

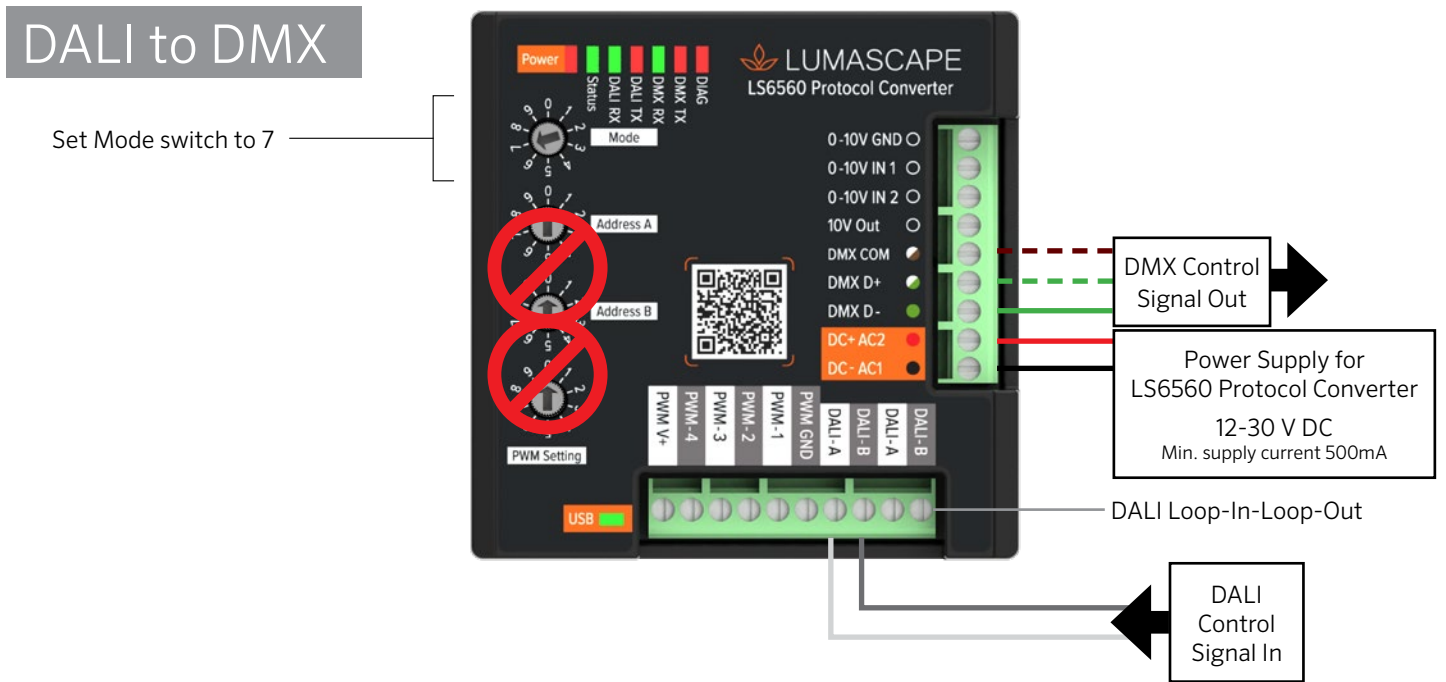

DAI TO DMX

The DMX output can be used as the control protocol to feed into a PowerSync Data Injector.

Compatible models are:

LS6540 Mains Voltage PS4 Data Injector

LS6550 Low Voltage PS4 Data Injector

LS6555 Low Voltage PS5 Data Injector

For details refer to corresponding installation instructions.

FEATURES

- ✓ Support for linear or logarithmic dimming curve via Application Extended Commands (DT6 device)
- ✓ Support for standard DALI fade times, fade rates, fast fade times, and extended fade times.
- ✓ Supports broadcast, group and individual addressing

INSTRUCTIONS

- 1** Set controller to DALI to DMX conversion mode.
- 2** Set **Mode** → 7
Address A → ~~Not Used~~
Address B → ~~Not Used~~
PWM Settings → ~~Not Used~~

In this mode, the Converter maps DALI input data to DMX output. The table below shows DMX-to-PWM channel mapping:

DALI Address	DMX Address
0	1
⋮	⋮
63	64

- 3** Connect wiring as per the diagram.
 PWM output is disabled in this mode.

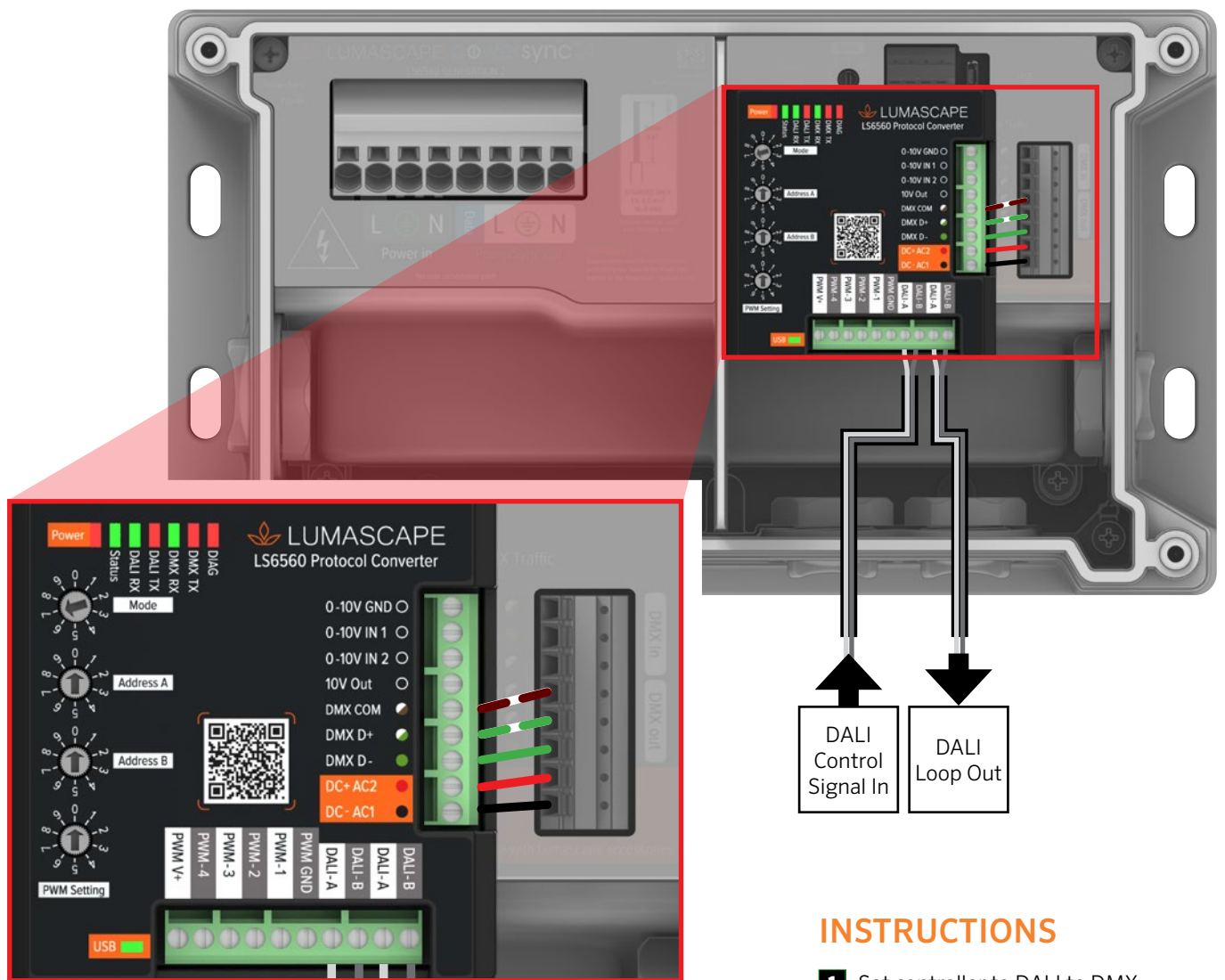

For instruction on setting-up the LS6540 Mains Voltage PS4 Data Injector GEN2 refer to installation instruction IN0226GEN2.



FEATURES

- ✓ Support for linear or logarithmic dimming curve via Application Extended Commands (DT6 device)
- ✓ Support for standard DALI fade times, fade rates, fast fade times, and extended fade times.
- ✓ Supports broadcast, group and individual addressing

INSTRUCTIONS

- 1 Set controller to DALI to DMX conversion mode.
- 2 Set **Mode** → 7
Address A → Not Used
Address B → Not Used
PWM Settings → Not Used

In this mode, the Converter maps DALI input data to DMX output. The table below shows DMX-to-PWM channel mapping:

DALI Address	DMX Address
0	1
⋮	⋮
63	64

- 3 Use double sided adhesive tape to attach the LS6560 to the LS6540 as shown.
- 4 Connect wiring as per the diagram.
 PWM output is disabled in this mode.

0-10V to PWM

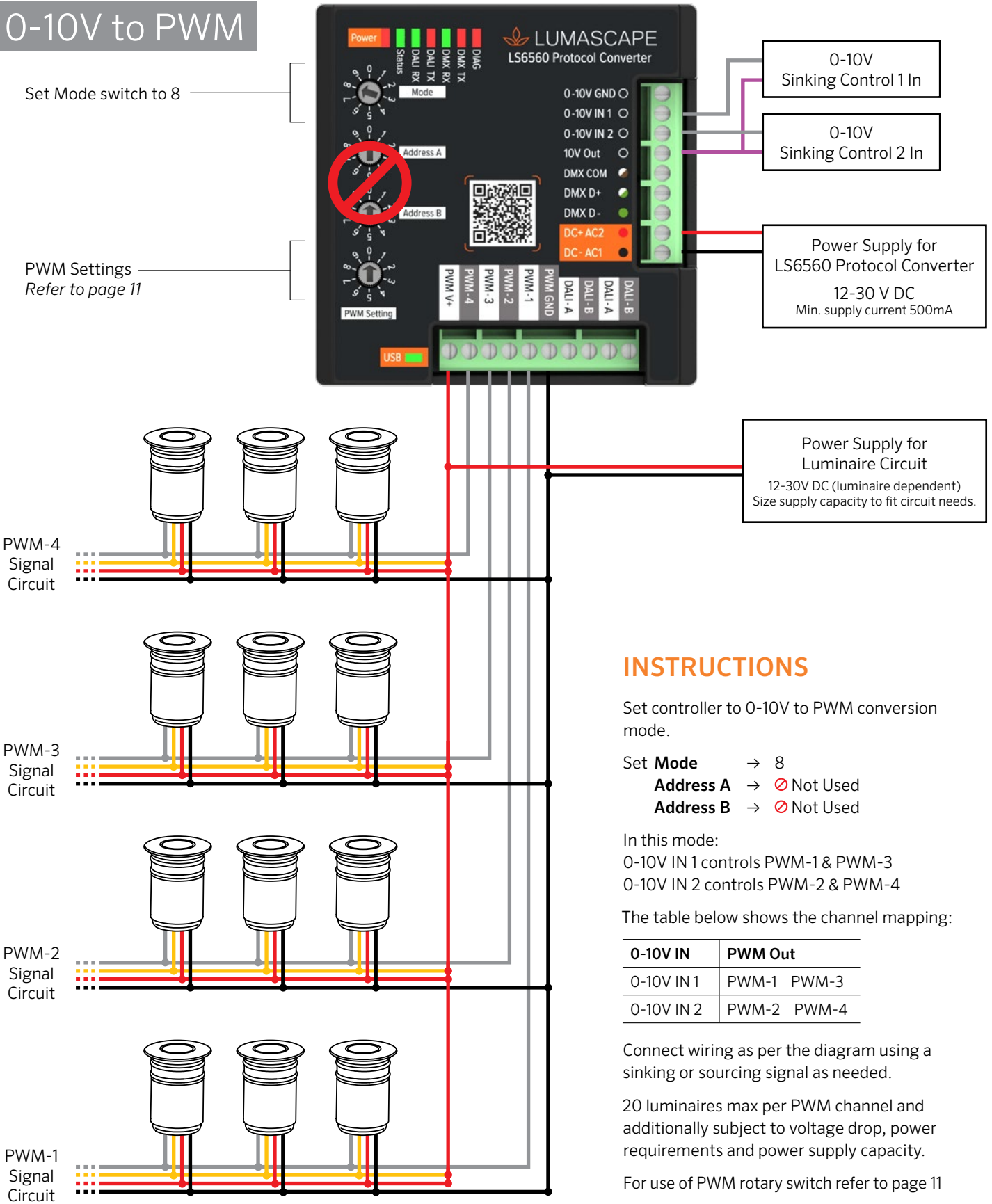

INSTRUCTIONS

Set controller to 0-10V to PWM conversion mode.

- Set **Mode** → 8
- Address A** → ~~Not Used~~
- Address B** → ~~Not Used~~

In this mode:
 0-10V IN 1 controls PWM-1 & PWM-3
 0-10V IN 2 controls PWM-2 & PWM-4

The table below shows the channel mapping:

0-10V IN	PWM Out
0-10V IN 1	PWM-1 PWM-3
0-10V IN 2	PWM-2 PWM-4

Connect wiring as per the diagram using a sinking or sourcing signal as needed.

20 luminaires max per PWM channel and additionally subject to voltage drop, power requirements and power supply capacity.

For use of PWM rotary switch refer to page 11

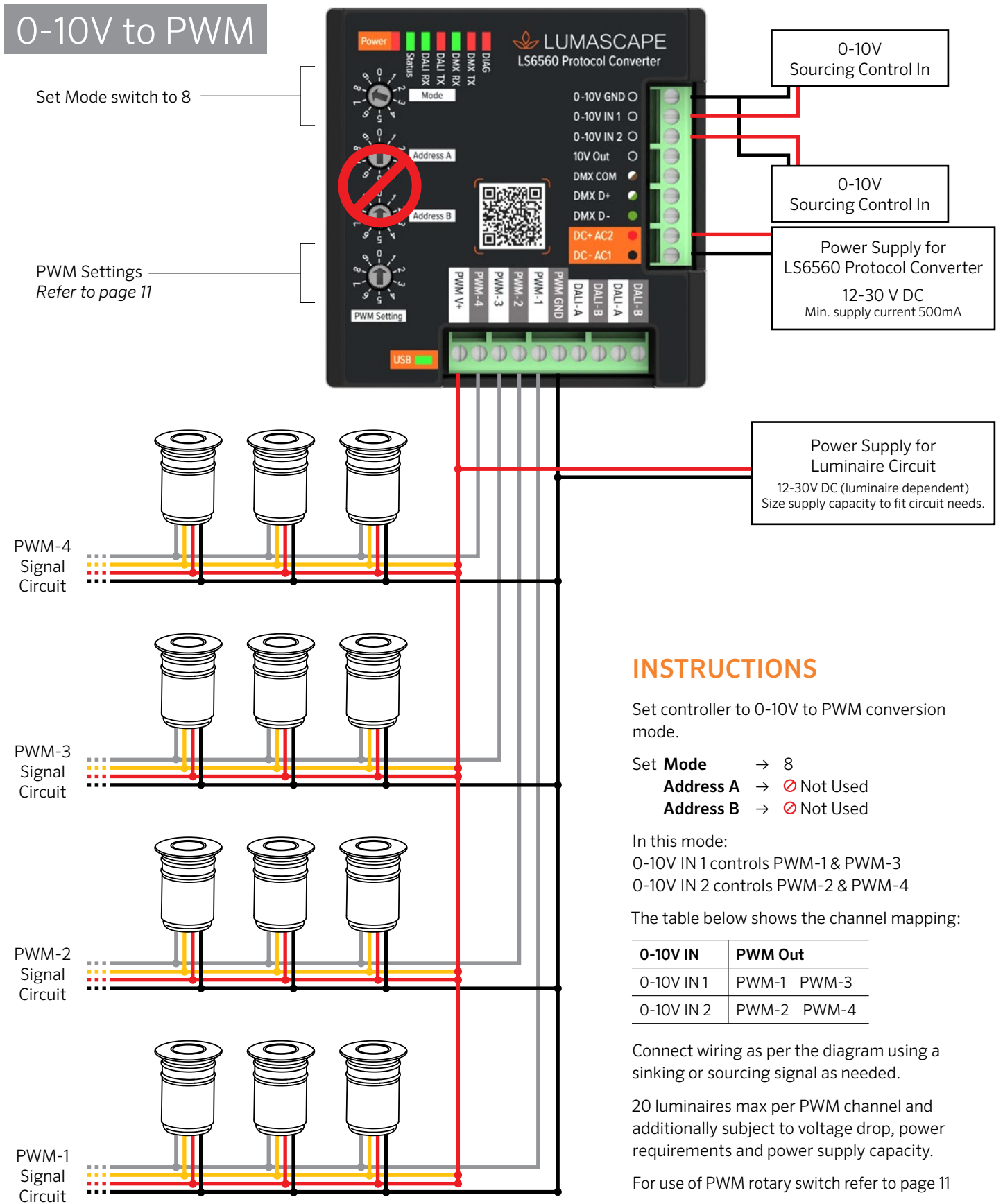

0-10V Sinking to PWM

Using Lutron Nova T NTSTV-DV

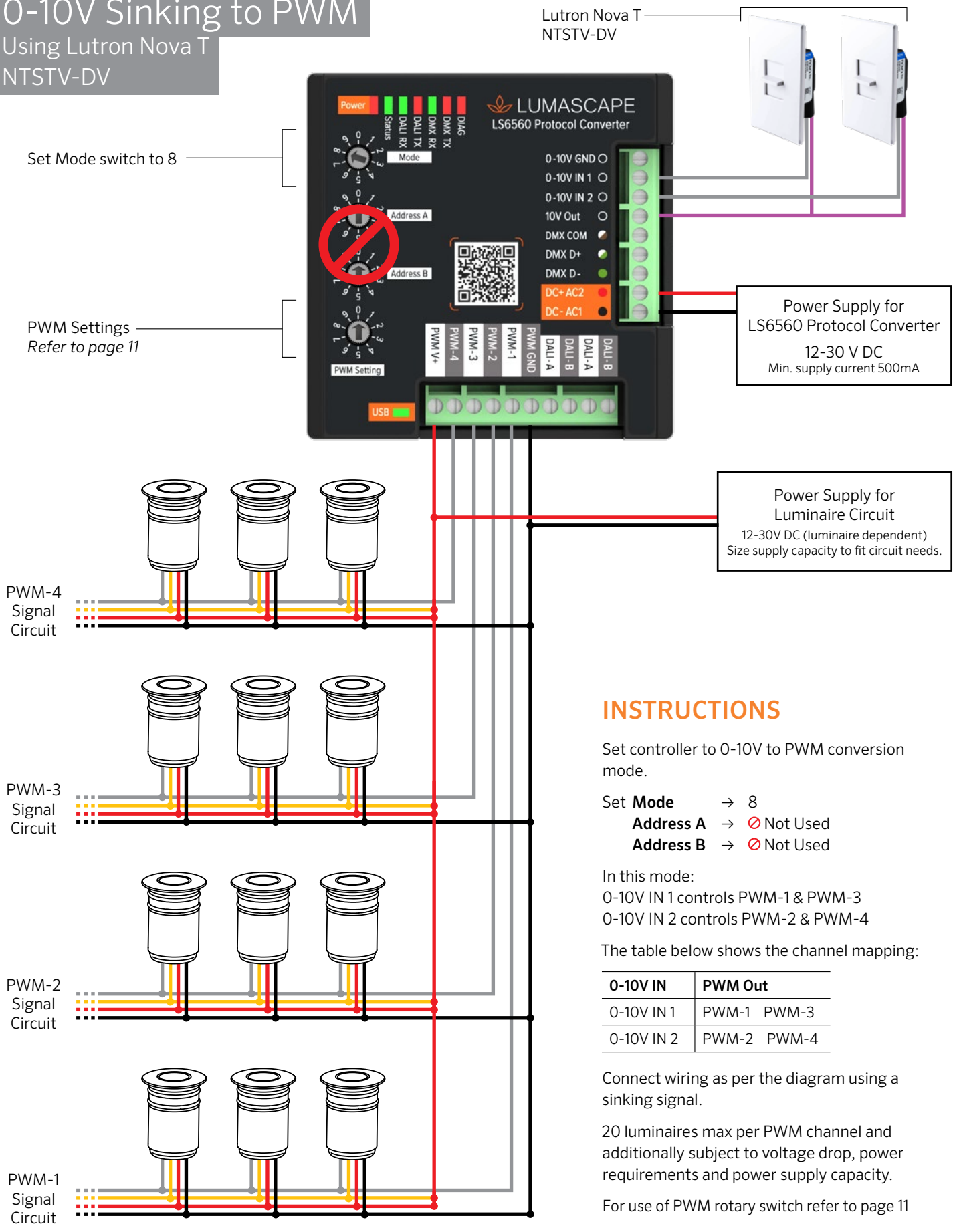

INSTRUCTIONS

Set controller to 0-10V to PWM conversion mode.

- Set **Mode** → 8
- Address A** → ~~Not Used~~
- Address B** → ~~Not Used~~

In this mode:
 0-10V IN 1 controls PWM-1 & PWM-3
 0-10V IN 2 controls PWM-2 & PWM-4

The table below shows the channel mapping:

0-10V IN	PWM Out
0-10V IN 1	PWM-1 PWM-3
0-10V IN 2	PWM-2 PWM-4

Connect wiring as per the diagram using a sinking signal.

20 luminaires max per PWM channel and additionally subject to voltage drop, power requirements and power supply capacity.

For use of PWM rotary switch refer to page 11

PWM Settings

Value	PWM Frequency
0	100Hz
1	200Hz
2	400Hz
3	800Hz
4	1600Hz
5	Inv-100Hz
6	Inv-200Hz
7	Inv-400Hz
8	Inv-800Hz
9	Inv-1600Hz

TROUBLESHOOTING

If the luminaire is going the opposite of what is expected e.g. off instead of on or dim instead bright it is suggested to use an inverted signal.

Some luminaires have trouble with high frequency PWM input signals. In such a case it is suggested to gradually reduce the PWM frequency until the luminaire behaves as expected.

■ Use for all PWM enabled Lumascape products.

PWM Compatible Lumascape Products

LS121LED Cassia LED

LS192LED Grevillea LED

LS192LED-2 Double Grevillea LED

LS201LED Hakea LED

LS321LED Pagoda LED

LS321LED-2 Double Pagoda LED

LS940xLED Vedita LED

LS411LED Omnio LED

LS553LED Via LED

LS563LED Vedi LED

LS722LED Magnolia LED

LS731LED Portico LED

LS741LED Piazza LED

LS751LED Villa LED

LS751LED-2 Double Villa LED

LS782LED Astelia LED

LS793LED Evoca LED

LS333ANS-2LED Nero LED

LS333ANS-COB Nero COB

Physical Installation - DIN Rail Mount

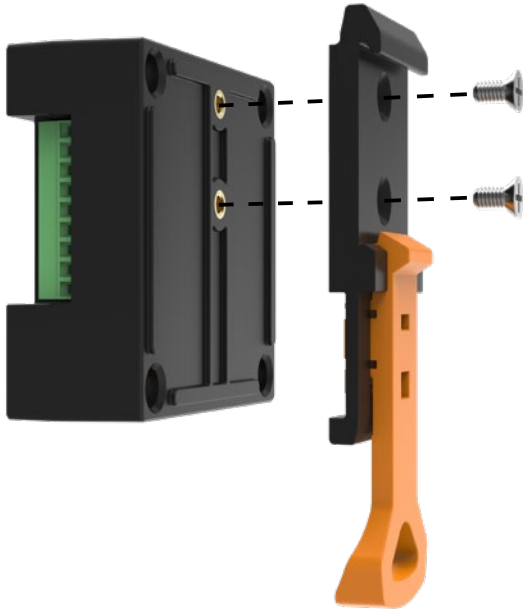

Attach DIN Rail clip to the body of the LS6560 Protocol Converter using the screws provided.

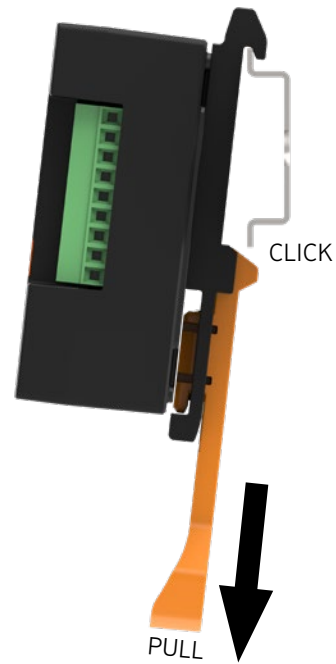

Pull down the orange, spring loaded handle to clip the LS6560 Protocol Converter into the DIN Rail.



LS6560 Protocol Converter mounted to DIN Rail.

LS6560 must be installed in a suitable, weather proof enclosure and in compliance with local wiring regulations.

Physical Installation - Inside LS6540

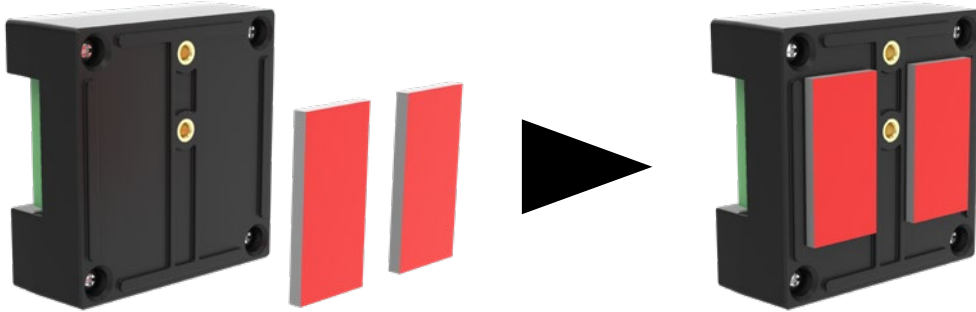

Attach the adhesive tape to the LS6560 Protocol Converter.

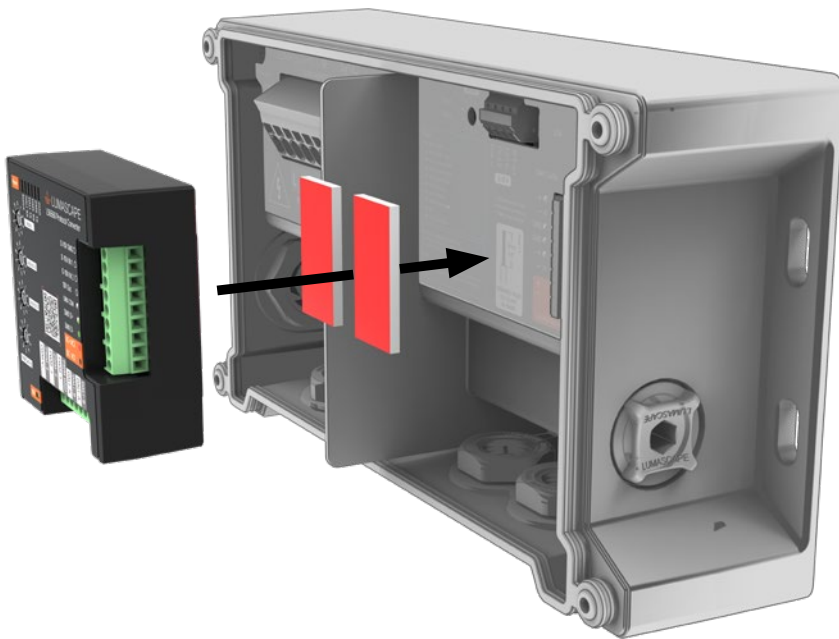

Attach the LS6560 Protocol Converter to the LS6540 DataSync™ Data Injector as shown in diagram.



LS6560 Protocol Converter mounted inside LS6540 DataSync™ Data Injector. Refer to page 7 for wiring and setup details.

Mode Table

The table below shows what functions are available when the Mode setting is in each position from 0-9.



DMX to PWM										
Mode ->	0	1	2	3	4	5	6	7	8	9
Mode	DMX 0xx	DMX 1xx	DMX 2xx	DMX 3xx	DMX 4xx	DMX 5xx				
Address A	DMX x0x	DMX x1x	DMX x2x	DMX x3x	DMX x4x	DMX x5x	DMX x6x	DMX x7x	DMX x8x	DMX x9x
Address B	DMX xx0	DMX xx1	DMX xx2	DMX xx3	DMX xx4	DMX xx5	DMX xx6	DMX xx7	DMX xx8	DMX xx9
PWM Setting	100Hz	200Hz	400Hz	800Hz	1600Hz	100Hz (Inv)	200Hz (Inv)	400Hz (Inv)	800Hz (Inv)	1600Hz (Inv)

For more information refer to page 4

DMX to PWM										
Mode ->	0	1	2	3	4	5	6	7	8	9
Address A	DALI 0x	DALI 1x	DALI 2x	DALI 3x	DALI 4x	DALI 5x	DALI 6x			DALI Soft Add
Address B	DALI x0	DALI x1	DALI x2	DALI x3	DALI x4	DALI x5	DALI x6	DALI x7	DALI x8	DALI x9
PWM Setting	100Hz	200Hz	400Hz	800Hz	1600Hz	100Hz (Inv)	200Hz (Inv)	400Hz (Inv)	800Hz (Inv)	1600Hz (Inv)

For more information refer to page 5

DMX to PWM										
Mode ->	0	1	2	3	4	5	6	7	8	9
Address A										
Address B										
PWM Setting	100Hz	200Hz	400Hz	800Hz	1600Hz	100Hz (Inv)	200Hz (Inv)	400Hz (Inv)	800Hz (Inv)	1600Hz (Inv)

For more information refer to page 6

DMX to PWM										
Mode ->	0	1	2	3	4	5	6	7	8	9
Address A										
Address B										
PWM Setting	100Hz	200Hz	400Hz	800Hz	1600Hz	100Hz (Inv)	200Hz (Inv)	400Hz (Inv)	800Hz (Inv)	1600Hz (Inv)

For more information refer to page 7

DMX to PWM										
Mode ->	0	1	2	3	4	5	6	7	8	9
Address A										
Address B										
PWM Setting	100Hz	200Hz	400Hz	800Hz	1600Hz	100Hz (Inv)	200Hz (Inv)	400Hz (Inv)	800Hz (Inv)	1600Hz (Inv)



Asia Pacific

Brisbane Technology Park
77 Brandl Street, Eight Mile Plains
Queensland, 4113, Australia
P: +61 7 3854 5000
F: +61 7 3854 5001
E: sales@lumascape.com

North America

1940 Diamond Street, San Marcos
California, 92078, United States
P: +1 650 595 5862
F: +1 650 595 5820
E: info@lumascape.com